



## MAG flow meter



## Installation Manual





## IMPORTANT WARNING



IT IS VERY IMPORTANT THAT ALL PERSONNEL WORKING WITH THE EQUIPMENT HAVE READ AND UNDERSTAND THE INSTRUCTIONS AND DIRECTIONS PROVIDED IN THIS MANUAL AND THEY FOLLOW THE INSTRUCTIONS AND DIRECTIONS BEFORE TAKING THE EQUIPMENT INTO USE. THE MANUFACTURER ACCEPTS NO LIABILITY FOR THE CONSEQUENCES OF MISUSE BY THE OPERATOR.

The operator shall bear responsibility for the suitability of the device for the specific purpose:

1. Improper installation and operation of the devices (systems) will cause warranty to be void
2. The manufacturer will not be liable for any damage of any kind by using its product, including, but not limited direct, indirect, incidental, punitive and consequential damages.  
Installation, connection, commissioning and service must be carried out by personnel who are qualified and authorized to do so.  
Installation personnel must ensure that the measuring system is correctly connected in accordance with the connection diagram.  
For applications involving high working pressures or media that can be dangerous to people, surroundings, equipment or other in the event of pipe fracture, BMETERS SRL recommends taking precautions such as special placement, shielding or installation of a safety guard or safety valve prior to installation of the sensor.

This device contains electrical components with an electrical current therefore installation, services and maintenance must be carried out by expert and qualified personnel, aware of all necessary precautions. Before opening any internal parts, please shut off the power supply. This manual refers to a flowmeter in compliance with EN 50082, -2 (immunity) AND EN50081-2 (emissions), belonging to class A.

The flowmeter is composed of metal and plastic parts, all of which must be in compliance with local norms and requirements concerning their trash disposal.

READ AND KEEP THESE INSTRUCTIONS IN A SAFE PLACE

 <b>WARNING!</b>	
 <small>DANGEROUS ELECTRIC CURRENT</small>	RISK OF ELECTRIC SHOCK ANY OPERATIONS INDICATED BY THIS SYMBOL, MUST BE CARRIED OUT EXCLUSIVELY BY QUALIFIED TECHNICAL PERSONNEL .

 <b>WARNING!</b>	
	VITALLY IMPORTANT INFORMATION AND POINTS TO OBSERVE. PLEASE SEE THE ASSOCIATED DOCUMENTS

<b>NOTE</b>	
	INFORMATION AND PARTICULARLY IMPORTANT POINTS TO OBSERVE

CE/EMC/Standards



The manual describing this flowmeter complies to the following safety rules:

- EMC Directives 89/336/EEC AND 93/68/EEC; EN 61326-1 (1997), A1(1998), A2 (2001), A3(2003)
- Low Voltage Directives 73/23/EEC and 93/68/EEC
- It belongs to class A.

It is also essential to read the start up manual accompanying the flowmeter and contained in the packaging.

## Manufacturer's design and safety statement

- Responsibility for the choice of lining and electrode materials as regards abrasion and corrosion resistance lies with the purchaser; the effect of any change in process medium during the operating of the meter should be taken into account. Incorrect selection of lining and/or electrode could lead to a failure of the meter.
- Stresses and loading caused by earthquakes, traffic, high winds and fire damage are not taken into account during meter design.
- Do not install the meter such that it acts as a focus for pipeline stresses. External loading is not taken into account during meter design.
- During operation do not exceed the pressure and/or temperature ratings indicated on the data label or in this Operating Manual.

## Battery operation:

- RS485, 4...20 mA outputs must be always feed by an external 24V power supply complying with Low Voltage Directive (LVD) in order to be considered safe.
- Lithium batteries are primary power sources with high energy content. They are designed to meet the highest possible safety standard. They may, however, present a potential hazard if they are abused electrically or mechanically. This is in most circumstances associated with the generation of excessive heat, where increased internal pressure may cause the cell to rupture.  
Thus the following basic precautions should be observed when handling and using lithium batteries:
  - Do not short-circuit, recharge, overcharge or connect with false polarity
  - Do not expose to temperature beyond the specified temperature range or incinerate the battery - Do not crush, puncture or open cells or disassemble battery packs
  - Do not weld or solder to the body of the battery, or the battery packs - Do not expose contents to water
- Lithium batteries are regulated under United Nations Model Regulations on Transport of Dangerous goods, UN document ST/SGAC. 10-1, 12th revised edition, 2001. UN no. 3091 class 9 covers lithium batteries packed with or inside the equipment. UN no. 3090 class 9 covers transportation of batteries on their own.  
Thus the following basic precautions should be followed when transporting lithium batteries:
  - Transport only in special packaging with special labels and transportation documents.
  - Exercise caution in handling, transportation and packaging in order to prevent short circuiting of the batteries.
  - The gross mass of the package is limited according to the type of transportation. In general a gross mass below 5 Kg is acceptable for all forms of transportation.
- Remove the battery from transmitter before returning the flowmeter to BMETERS International for service or warranty claim.

<b>1. PRELIMINARY NOTES</b>	<b>7</b>
<b>2. GENERAL PRECAUTIONS</b>	<b>7</b>
<b>3. INSTALLATION OF THE SENSOR</b>	<b>9</b>
3.1. IDENTIFYING DATA PLATE	9
3.2. Direction of the liquid in the sensor indicated by the arrow	9
3.3. Installation instructions	10
3.3.1 Positioning in relation to the plant	10
3.3.2 Positioning in relation to the flow	10
3.3.3 Important bonding indications	11
3.3.4 Charts of maximum allowable torques	12
3.3.5 Important guidelines for correct installation	13
3.3.6 Important generic indications for a correct installation	16
<b>4. POTENTIAL EQUALIZATION</b>	<b>19</b>
<b>5. NEGATIVE PRESSURE IN THE PIPE</b>	<b>21</b>
<b>6. CONVERTER MAG</b>	<b>23</b>
6.1. Installation	23
6.1.1 Identifying data plate	23
6.1.2 Compact version	23
6.1.3 Remote version	24
6.1.4 Electrical connections	26
6.1.5 RS485 MODBUS Output	27
6.1.6 Electrical grounding of the converter	27
6.1.7 Connection to the power supply	27
6.2. Programming of MAG converter	28
6.2.1 Programming	30
6.3. Alphabetical list of functions	31
<b>7. MENU DESCRIPTION</b>	<b>33</b>
<b>8. RETURNING A FLOWMETER FOR CHECKING OR REPAIRING</b>	<b>43</b>
<b>9. APPENDIX - TROUBLESHOOTING</b>	<b>45</b>

## 1. PRELIMINARY NOTES

The main parts composing the electromagnetic flowmeter are:

- A. The sensor - is installed in the pipes using flanges or threaded attachments or clamp attachments
- B. The converter - may be installed on the sensor (in compact version), or nearby (in remote version) connected by two cables.

Electromagnetic water meters have many important advantages over their mechanical counterparts: outstanding long term stability, maximum process reliability, no maintenance - to name just a few. As a result, these meters can deliver precise and reliable measurements for many years.

NOTE	
	<p>Electromagnetic flowmeters are specifically designed to work under few basic conditions:</p> <ol style="list-style-type: none"> <li>1. Liquid must be conductive</li> <li>2. Full pipe conditions at any time</li> <li>3. Recommended inlet and outlet distances</li> </ol>

Please see below paragraphs for more detailed indications on the correct installation.

## 2. GENERAL PRECAUTIONS

The correct lifting method is shown in the figure on the right, while the one shown in the figure on the left should be avoided; more importantly DO NOT lift the flowmeter by its converter but by holding it on its sides.



f. 1



f. 2



In addition:

DO NOT move the flowmeter with the lifting device without the original packaging or without the help of an appropriate support, offering the same stability.

f.3

### 3. INSTALLATION OF THE SENSOR

#### 3.1 IDENTIFYING DATA PLATE

The plate located on the sensor carries the following data:

MODEL	MUT 2200EL	
PART N°	WAC 276	
DN	8"	PN 16
Temp.	80°	IP 68
ELECTRODES	H-C	
LINING	PTFE	
KA	+2.6428	
KB	-007641	
ITEM		
STD Flange A150 Made in Italy		
		

- MODEL:
- PART N°: part number identifying the instrument (identification number for tracing identity)
- DN: nominal diameter [inches or mm]
- PN nominal pressure [bar]
- Temp.: maximum temperature of the fluid to process
- IP: degree of international protection
- ELECTRODES: material composition of the electrodes
- LINING: internal lining material
- KA: calibration coefficients
- ITEM: other particular guidelines

f. 4

#### 3.2 DIRECTION OF THE LIQUID IN THE SENSOR INDICATED BY THE ARROW

In the sensor, if the liquid flows:

- in the same direction of the arrow (enter by - and exit by +), the flow is positive, the display will show reading with no sign;
- in the opposite direction to that indicated by the arrow (enter by + and exit by -), the flow is negative, the display will show reading with negative sign;



From - to +	-	→ direct flow	-	→ digit without sign
From + to -	-	→ inverse flow	-	→ negative digit

3.3 INSTALLATION INSTRUCTIONS

<b>IMPORTANT NOTE</b>	
	THE SENSOR MUST ALWAYS BE COMPLETELY FULL WITH LIQUID AT ANY TIME!

3.3.1 POSITIONING IN RELATION TO THE PLANT

For an efficient working condition, please carefully follow indications in figure 5.

The flowmeter must remain below the hypothetical blue line (piezometric level line) which connects the two levels of liquid to measure.

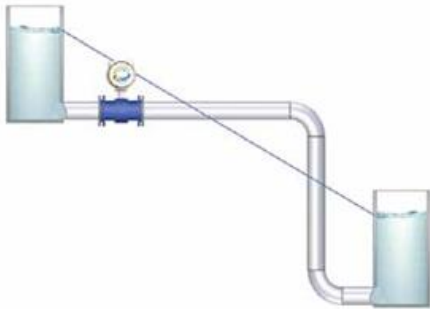

f. 5

Avoid placing the flowmeter above the piezometric level line.

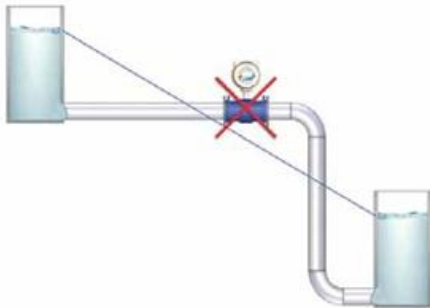

f. 6

3.3.2 POSITIONING IN RELATION TO THE FLOW

With installations in horizontal pipes, the converter (or the junction box in the separate version) must be placed on the upper part.

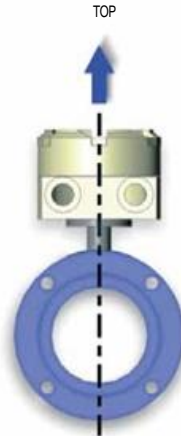

f. 7

In case of obstruction, follow the guidelines as explained in the lower figures:



f. 8

Avoid following positions:

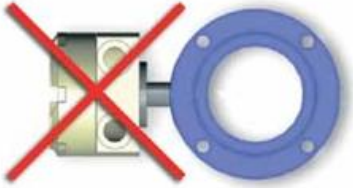

f. 9

Recommended installation is in vertical/inclined pipe with upward flow direction, to minimize the wear and deposits in the sensor. Avoid installation in vertical pipes with free outlet.

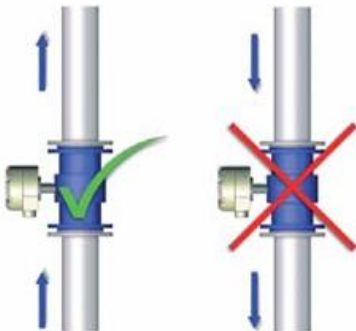

f. 10

3.3.3 IMPORTANT BONDING INDICATIONS

Use elastic pipe fittings in case of a not adequate distance between sensor and pipe. Do not attempt to bring the pipe to the sensor by tightening the bolts.



f. 11

Max. Permissible deviation of pipe flange faces 0.5mm

$L_{max} - L_{min} \leq 5 \text{ mm}$ .

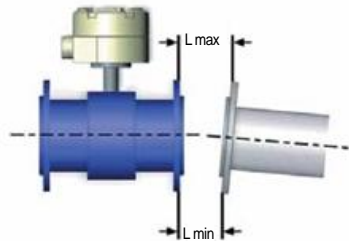

f. 12

3.3.4 CHARTS OF MAXIMUM ALLOWABLE TORQUES

Standard bolts must be well lubricated and tightened evenly around the gasket. Leakage/damage to the flowmeter or piping may arise if bolts are overtightened. Carefully follow the indications given by the charts, check carefully the correct centering of the sensor before securing the flanges and then proceed following the steps indicated below:

- Step 1. approx 50% of maximum torque;
- Step 2. approx 80% of maximum torque;
- Step 3. approx 100% of maximum torque given in the chart.



f. 13

All values are theoretical and calculated for optimum conditions and use with carbon steel flanges.

MUT 1100 PBT+ FIBERGLASS

Sensor	Max operative pressure		Flanges pipes		Max allowable torques	
	[bar]	[psig]	flange	class	[Nm]	[ftlb]
DN 40	≤10	≤145	DN 40	PN 16/40	25	13
DN 50	≤10	≤145	DN 50	PN 16/40	35	19
DN 65	≤10	≤145	DN 65	PN 16/40	35	19
DN 80	≤10	≤145	DN 80	PN 16/40	35	19
DN 100	≤10	≤145	DN 100	PN 16/40	45	24
DN 125	≤10	≤145	DN 125	PN 16/40	65	35
DN 150	≤10	≤145	DN 150	PN 16/40	85	45
DN 200	≤10	≤145	DN 200	PN 16/40	100	53
1 1/2"	≤10	≤145	1 1/2"	150/300	25	13
2"	≤10	≤145	2"	150/300	35	19
2 1/2"	≤10	≤145	2 1/2"	150/300	35	19
3"	≤10	≤145	3"	150/300	35	19
4"	≤10	≤145	4"	150/300	45	24
5"	≤10	≤145	5"	150/300	65	35
6"	≤10	≤145	6"	150/300	85	45
8"	≤10	≤145	8"	150/300	100	53

3.3.5 IMPORTANT GUIDELINES FOR CORRECT INSTALLATION

For a correct working condition please follow the important guidelines shown in the following figures. A wrong installation cannot guarantee a good measurement.

To achieve most accurate flow measurement it is essential to have minimum straight lengths of the inlet and outlet pipes as shown (DN: sensor nominal diameter)

- For partially filled pipes or pipes with downward flow and free outlet, the flowmeter should be located in a U-tube, respecting the upward and downward lengths between the bends.



f. 14

- In case of a "T" connection between two different pipes, please respect 10DN distance upstream the flowmeter.



f. 15

- Keep 5 meters between the axis of the flowmeter and the axis of the gate valve located downstream

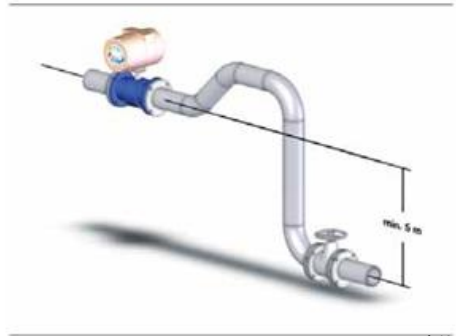

f. 16

RECOMMENDED INSTALLATIONS ( ) ✓

TO AVOID ( ✗ ):

IMPORTANT NOTE	
	<p>THE SENSOR MUST ALWAYS BE COMPLETELY FULL WITH LIQUID AT ANY TIME!</p>

- This installation keep the sensor full with liquid



f. 17

- This installation DOES NOT guarantee a full pipe condition.



f. 18

- DO NOT place any gate valve directly connected upstream the sensor.



f. 21

- The position on the left is correct, the other two ARE NOT.



f. 19

- Always install the sensor downstream the pump and NEVER upstream to avoid vacuum.



f. 22

- DO NOT place the sensor close to any variation in the route of the flow.



f. 20

- DO NOT install the sensor in vertical pipes with free outlet or at the highest point in the pipe system



f. 23

- Below installation methods are strongly recommended.

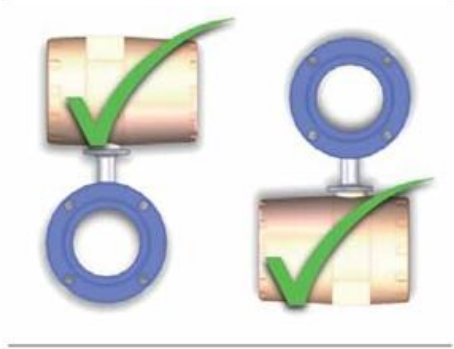

f. 26

- DO NOT USE the sensor as a support to the pipe.

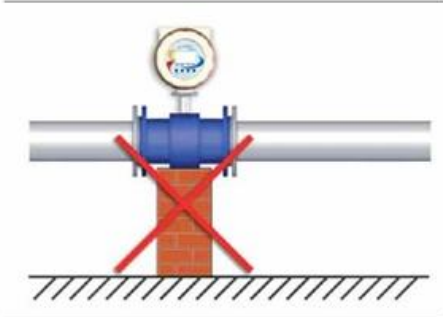

f. 24

- Pipe should give the support to the flowmeter

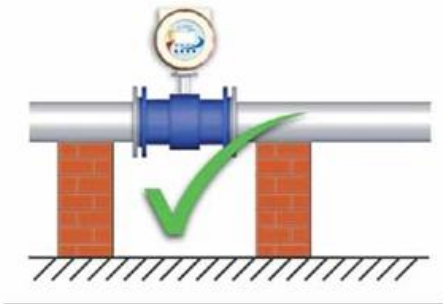

f. 25

- AVOID any of the following positions.

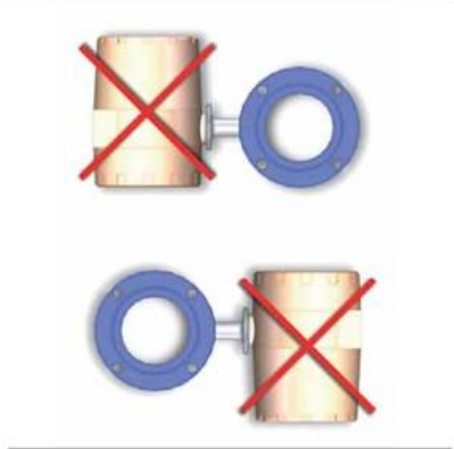

f. 27

BURIAL INSTALLATIONS

- Remote sensor is protected to IP68/NEMA 6P and can be buried. The use of pea gravel, at least 300mm (12inches) all around the sensor, is recommended. This provides some drainage and prevents dirt from solidifying on the sensor.

It also helps locate the sensor should excavation be necessary. Before covering the pea gravel with earth, we suggest using electrical cable identification tape above the gravel. Remote sensor cable should be run through a plastic conduit of 50mm (2 inches) minimum.

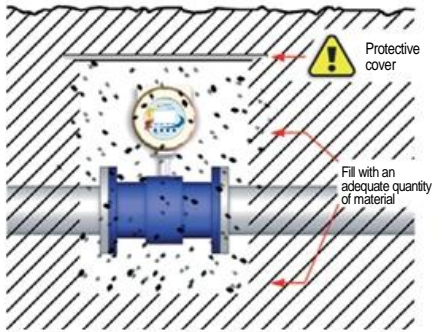

f. 28

3.3.6 IMPORTANT GENERIC INDICATIONS FOR A CORRECT INSTALLATION

- Install suitable antivibrational protection if any vibration arise.



f. 29

- DO NOT expose the flowmeter to vibrations and/or movement, which may affect its performance and duration.

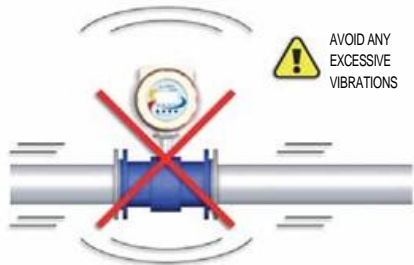

f. 30

- AVOID exposure of the flowmeter to strong or nearby magnetic fields.

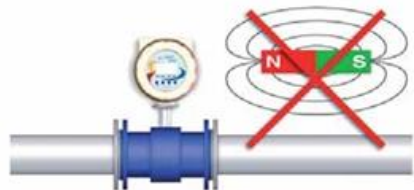

f. 31

- Protect the flowmeter if exposed to direct sun radiations.



f. 32



f. 33

- For a normal and efficient working of the flowmeter:
  - The environmental temperature should be limited on a range between  $(-25 \div +80) ^\circ\text{C}$ ,  $(-13 \div +176) ^\circ\text{F}$ ;  
Temperature of the motherboard available in the converter Menu  $\rightarrow$  Others  $\rightarrow$  time/date
  - The temperature of the liquid should be limited on a range between  $(-25 \div +80) ^\circ\text{C}$ ,  $(-13 \div +176) ^\circ\text{F}$  for compact version,  $(-25 \div +200) ^\circ\text{C}$ ,  $(-13 \div +392) ^\circ\text{F}$  for remote version .

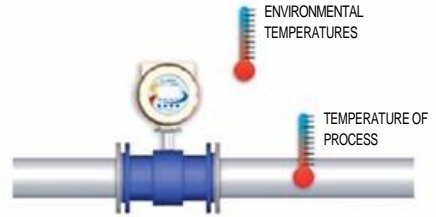

f. 34

## IMPORTANT NOTE



### NOTE FOR CONNECTION OF ATEX APPROVED FLOWMETERS

CABLING REQUIREMENTS IN POTENTIALLY EXPLOSIVE ATMOSPHERES (ATEX).

Lay the cables as required by standard EN 60079-14, in particular providing for mechanical protection thereof by, for example, rigid or flexible conduit pipes or the shelter of simple housing.



4. POTENTIAL EQUALIZATION

• Liquid potential equalization or grounding is accomplished with the built-in grounding electrode (so called 3rd electrode). The 3rd electrode electrically bond the liquid to the meter to provide a stable and accurate measurement.

IMPORTANT NOTE	
	THE SENSOR MUST ALWAYS BE GROUNDED! Wrong ground connection can lead to a wrong measurement

NOTE	
	The flowmeter is equipped with a grounding electrode (3rd electrode). Grounding rings are not necessary!

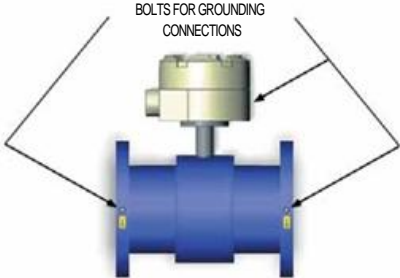

f. 35

• The sensor body must be grounded using grounding/bonding straps and/or grounding rings to protect the flow signal against stray electrical noise and/or lightning. This ensures that the noise is carried through the sensor body and noise-free measuring area within the sensor body

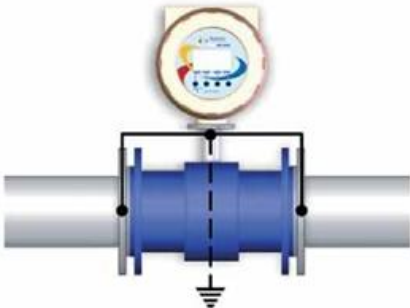

f. 36

•On plastic pipelines and lined metal pipes, OPTIONAL grounding rings can be used at both ends to ensure a good potential equalization. Grounding rings are not included in the delivery.



f. 37

• Special attention for meter installation in cathodic protected pipeline.

Isolate the meter from the pipeline by mounting isolation Sleeves and Washers on the flange bolts and connect a wire between the pipelines, dimensioned to manage the cathodic current and environmental influence. Use grounding rings on both ends.

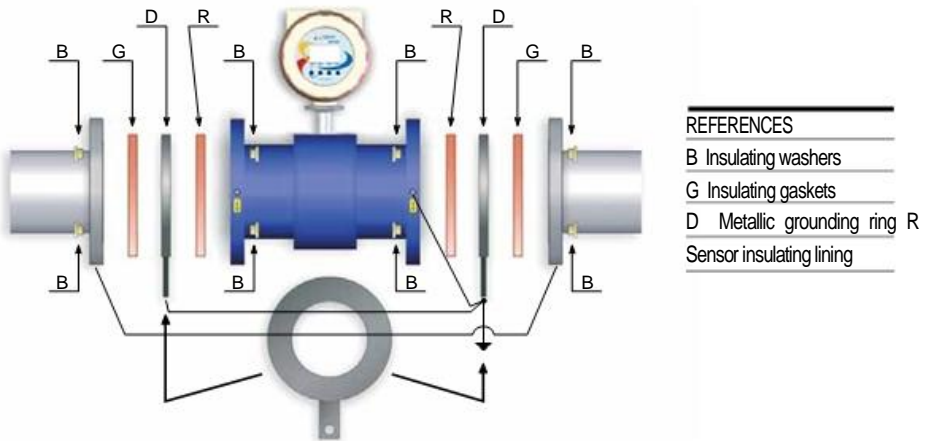

f. 38

## 5. NEGATIVE PRESSURE IN THE PIPE

Avoid high vacuum conditions in the pipe, these can damage the lining of the flowmeter and move the electrodes from the correct position.



## 6. CONVERTER MAG

### 6.1 INSTALLATION

#### 6.1.1 IDENTIFYING DATA PLATE

The data plate located on the converter displays the following information:

MODEL		IP	68
PART N°	WAP 320	Temp.	-20/+60°C
POWER S.	90-264 V	Hz	50/60
COUPLING	WAC 279		
OPTIONAL			

f. 39

- MODEL: converter model
- IP: degree of converter protection
- PART N°: serial number identifying the instrument
- Temp.: minimum/maximum temperature of working conditions
- POWER S: voltage supply or battery powered (MAG-B)
- HZ: frequency of voltage supply
- COUPLING: serial number identifying the sensor coupled to converter
- OPTIONAL: other modules that may be added

#### 6.1.2 COMPACT VERSION

Figure 40 represents the converter MAG in the compact layout.

##### • MAG

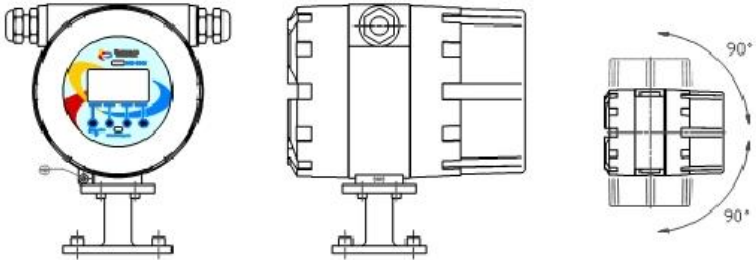

##### • MAG-B

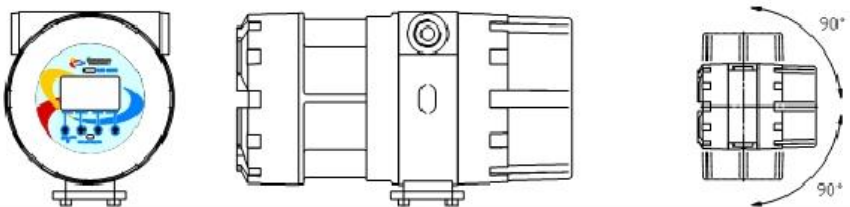

f. 40

When the converter is purchased in compact version all the electrical connections are already performed by the manufacturer.

Before running the converter, proceed with the outputs connection needed. For safety reasons wire the power supply only after having connected the outputs.

The converter can be rotated to a 90° angle by loosening the bolts on the lower part of the converter attached to the sensor neck. Once the new position of the converter is secured, close the bolts tight to ensure the converter on the sensor.

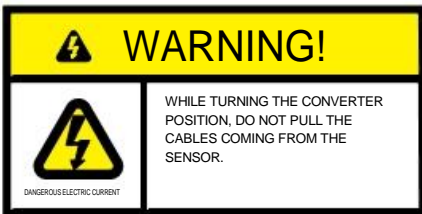

Avoid strong vibrations on the converter, use remote version in case vibrations may occur.

6.1.3 REMOTE VERSION



Figure 41 shows converter MAG in a remote version.

Cables coming from the sensor should be connected on the junction box located below the converter.

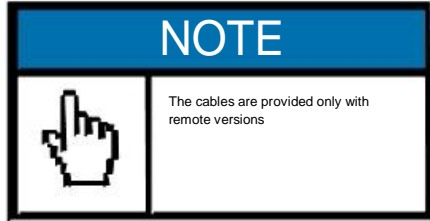

MAG converter may be either wall mounted or installed on a pole, using the tools supplied with remote version as shown in the figure.

The COUPLING value in the converter plate, shows the part number of the sensor to be connected. Such information is also set in the converter, please check Menu → Others → system info. The same info can be downloaded through the MAG software on your lap top.

To ensure smooth functioning, always use the signal cables included in the delivery by the manufacturer.

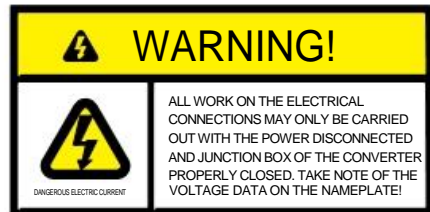
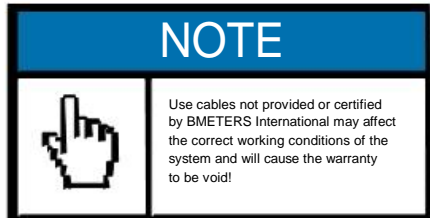

## • MAG

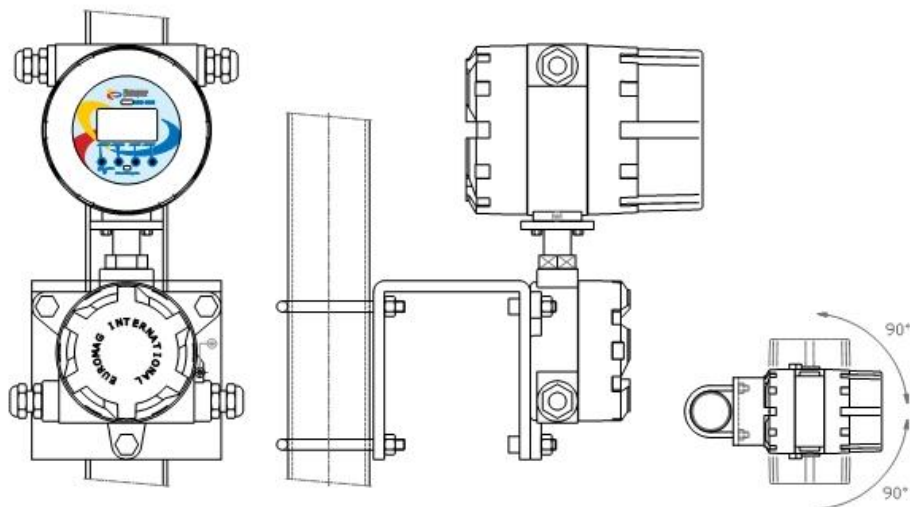

## • MAG-B

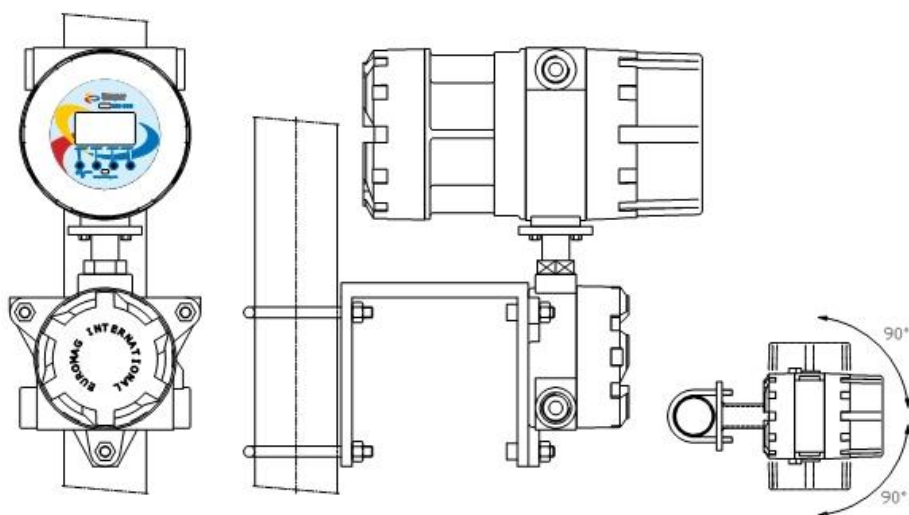

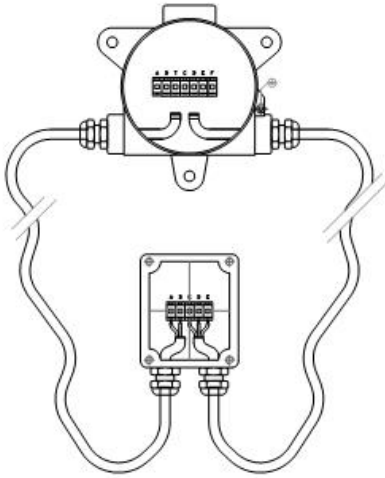

f. 42

<b>NOTE</b>	
	<p>THE JUNCTION BOX ON THE SENSOR IS DESIGNED TO BE IP68 PROTECTED ONLY WHEN PROPERLY CLOSED AND TIGHTENED. THE MANUFACTURER ACCEPTS NO LIABILITY OF AN IMPROPER CLOSURE BY THIRD PARTIES.</p>

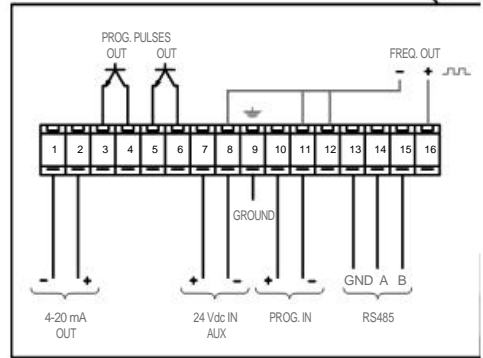
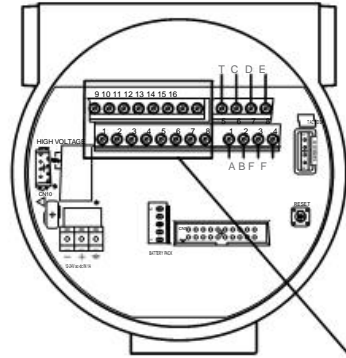

f. 43

**MAG Pulse Output Connection**

1. CLEAN CONTACT TYPICAL CONNECTION (suggested for battery operation MAG) Dataflow TX connection

**6.1.4 ELECTRICAL CONNECTIONS**

<b>⚠ WARNING!</b>	
 <small> DANGEROUS ELECTRIC CURRENT </small>	<p>ANY WORK DONE ON THE ELECTRICAL JUNCTION BOX OR ELECTRICAL COMPONENTS OF THE DEVICE MUST BE CARRIED OUT BY PROPERLY TRAINED SPECIALISTS</p>

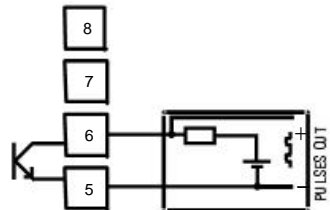
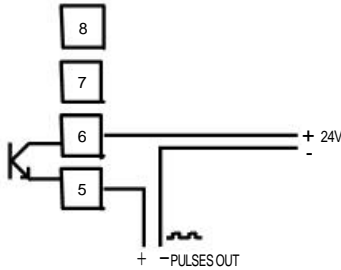

Figure 43 shows the Terminal block.

2. ACTIVE PULSES

(suggested for battery operation MAG-B)



3. ACTIVE PULSES WITH EXTERNAL 24V

(not suggested for battery operation converter)

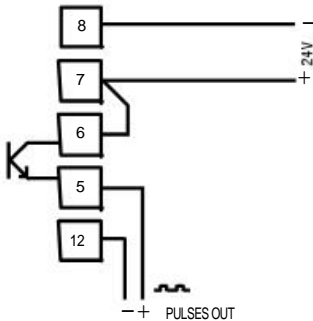

NOTE	
	<p>TOTAL NUMBER OF THE ON/OFF OUTPUT ABSORPTIONS (CURRENTS) MUST NOT EXCEED 100 mA</p>

6.1.5 RS485 MODBUS Output

The standard interface RS485 is available between clamps 14 - 15 of the block 4 in figure 43.

NOTE	
	<p>The RS485 output is a MODBUS standard communication port, compatible with any software able to communicate through MODBUS language, please refer to the MODBUS address menu for more information.</p>

6.1.6 ELECTRICAL GROUNDING OF THE CONVERTER CASE

The MAG case should be grounded. This connection should be carried out by grounding the bolt located in the lower part of the converter.

NOTE	
	<p>MAKING A PROPER CONNECTION IS NECESSARY FOR AN EFFICIENT WORKING OF THE DEVICE.</p>

6.1.7 CONNECTION TO THE POWER SUPPLY

⚠ WARNING!	
 <small> DANGEROUS ELECTRIC CURRENT </small>	<p>ELECTRICAL CONNECTION OF THE DEVICE MUST BE CARRIED OUT BY PROPERLY TRAINED SPECIALISTS</p>

Make sure all electrical connections are correctly performed before connecting the unit to the power supply. Check the power voltage on the name plate. The unit may be supplied with voltage:

- MAG
- 90 ... 264 Vac
- Or 12 ... 24 Vac/dc

MAG-B

Battery powered by Lithium battery pack Or  
12 ... 24 Vac/dc

6.2 PROGRAMMING OF THE MAG CONVERTER

MAG configuration can be performed in different ways:

- Through the 4 push buttons located on the front mask of the converter, unscrewing the front panel glass
- Via PC through the RS485 MODBUS output (see electrical connections) and the configuration software program BMETERS MAG. USB cable adapter available under request from the manufacturer
- Via PC through the IrDA port located on the front of the converter on top of the display and the configuration software program BMETERS MAG

MAG configuration is made via PC using BMETERS MAG software program.

- Use a USB adapter for direct communication to PC (available under request from the manufacturer) or an IrDA interface unit.
- Install the MAG software in your PC run the program, connect the unit to the PC and turn it on with the magnet (for MAG-B), select RS485 or IrDA communication and press on the CONNECT button (see below screen shot of the MAG program).

NOTE



RS485, 4...20 mA and frequency outputs must be always feed by an external 24V power supply.

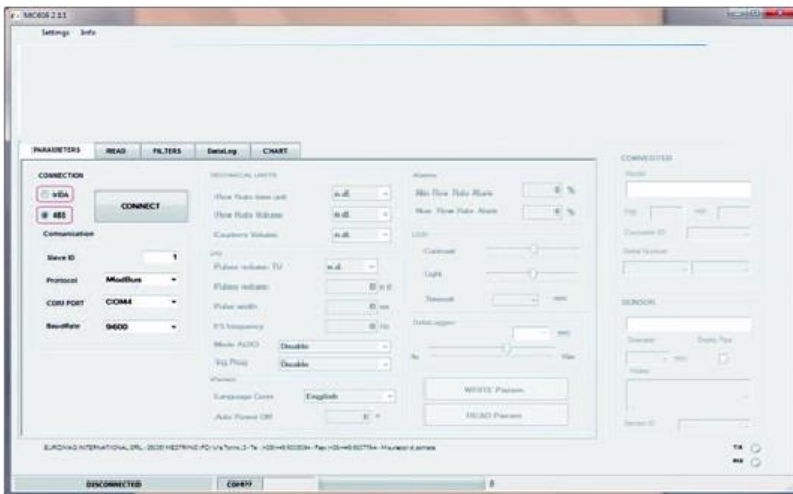

Select IrDA or 485 communication for the main page of the software.

ACTIVATING MAG-B

Normal operation of the MAG-B is to operate in “sleep mode”. Sleep mode conserves battery life while continuing functional operation of the product.

To wake the unit for programming or reading the values on the display, use the supplied magnetic fob and swipe it vertically on the front mask of the converter, where indicated by the word: “activate”

CONVERTER PASSWORDS:

The converter is built with three different level of protections. Passwords can be modified.

I level: 608111

II level: 709222

III level: 231042

MAG correctly connected: Parameters can now be read and modified:

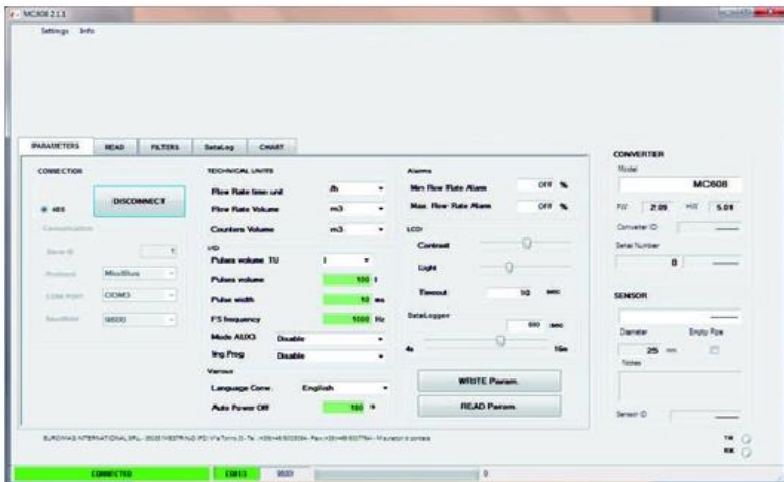

6.2.1 PROGRAMMING

To access the menu from the converter, simply press on the relevant button below the function. Enter the Menu by pressing the Menu button.

NOTE



All programmings can be done either on the converter through the push buttons, or using the BMETERS MAG software program

MENU

- Options
- Counters
- Parameters
- I/O
- Others
- Memory

Follow the below chart for an overview of the available functions.

OPTIONS	PARAMETERS	OTHERS
Technical units <ul style="list-style-type: none"> <li>• Flow rate volume</li> <li>• Flow rate time base</li> <li>• Counters volume</li> <li>• Pulses volume</li> </ul> Measurement frequency <ul style="list-style-type: none"> <li>• Measuring time</li> </ul> Display <ul style="list-style-type: none"> <li>• LCD backlight lev</li> <li>• Backlight off</li> <li>• LCD contrast</li> </ul> View options <ul style="list-style-type: none"> <li>• Last row</li> </ul> Full scale flow rate Language	Ka setup Diameter Setup Filters setup <ul style="list-style-type: none"> <li>• Flow cut off</li> <li>• Damping</li> <li>• Bypass</li> <li>• Peak cut</li> <li>• Measure average</li> </ul> Sensor offset Zero finder Flowrate alarms <ul style="list-style-type: none"> <li>• Max flow th.</li> <li>• Min flow th.</li> </ul>	System info Time/date Reserved Graph Simulation Communication <ul style="list-style-type: none"> <li>• Baudrate RS485</li> <li>• MODBUS address</li> </ul>
COUNTERS T+ P+ (set zero) T- P- (set zero)	I/O Pulses OUT <ul style="list-style-type: none"> <li>• Pulse volume</li> <li>• Pulse T on</li> </ul> Frequency OUT <ul style="list-style-type: none"> <li>• Full scale freq.</li> </ul> Prog. OUT <ul style="list-style-type: none"> <li>• Enabled/disabled</li> </ul> Prog. IN <ul style="list-style-type: none"> <li>• Enabled/disabled</li> </ul>	MEMORY Load user copy Save user copy Factory settings Datalogger <ul style="list-style-type: none"> <li>• Show last row</li> <li>• Full erase</li> <li>• Log interval</li> </ul>

6.3 ALPHABETICAL LIST OF FUNCTIONS

In the following tables the functions present in the menu and submenu of converter MAG are shown in alphabetical order

SUBMENU	MAIN MENU	SUBMENU
backlight off	Options	Display
Baudrate RS485	Others	-
Bypass	Parameters	Filters setup
Communication	Others	-
Counters Volume	Options	Technical units
Damping	Parameters	Filters setup
Datalogger	Memory	-
Diameter Setup	Parameters	-
Display	Options	-
Factory Settings	Memory	-
Filters setup	Parameters	-
Flow cut off	Parameters	Filters setup
Flow rate volume	Options	Technical units
Flow rate time base	Options	Technical units
Flow rate alarms	Parameters	-
Frequency OUT	I/O	-
Full erase	Memory	Datalogger
Full scale flow rate	Options	-
Full scale freq.	I/O	Frequency OUT
Graph	Others	-
Ka setup	Parameters	-
Language	Options	-
LCD backlight level	Options	Display
LCD contrast	Options	Display
Load user copy	Memory	-
Last row	Options	View options
Log interval	Memory	Datalogger

SUBMENU	MAIN MENU	SUBMENU
Measure average	Parameters	Filters setup
Measurement freq.	Options	-
Measuring time	Options	Measurement freq.
Min flow th.	Parameters	Flow rate alarms
Max flow th.	Parameters	Flow rate alarms
MODBUS address	Others	Communication
P-	Counters	-
P+	Counters	-
Peak cut	Parameters	Filters setup
Prog. IN	I/O	-
Prog. OUT	I/O	-
Pulse T on	I/O	Pulses OUT
Pulse volume	I/O	Pulses OUT
Pulses OUT	I/O	-
Pulses volume	Options	Technical units
Reserved	Others	-
Save user copy	Memory	-
Sensor offset	Parameters	-
Show last row	Memory	Datalogger
Simulation	Others	-
System info	Others	-
T+	Counters	-
T-	Counters	-
Technical units	Options	-
Time/date	Others	-
View options	Options	-
Zero finder	Parameters	-

DATA TO BE DISPLAYED

The display is divided into 3 main areas.

Top area with symbols for status information, with battery life indication (MAG-B), alarms symbols, and instant reading flowrate.

Middle area with linear graph of the flowrate shown in percentage on the full scale flow rate.

Below area can be selected by the customer, choices are the followings:

- T+ total positive counter
- P+ partial positive counter
- T- total negative counter
- P- partial negative counter
- Date and time

To select the requested value simply click on the button corresponding to the arrow and make your choice, or select Menu → Options → View options → last row

ALARM VISUALIZATION

There are three different alarms that can be visualized on the display:

- Empty pipe alarm (only available with sensor with the 4th electrodes)

- Max flow alarm

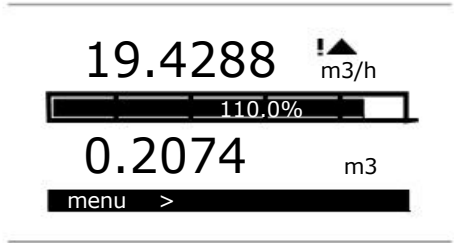

f. 47

- Min flow alarm

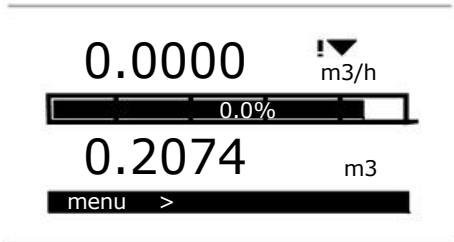

f. 48

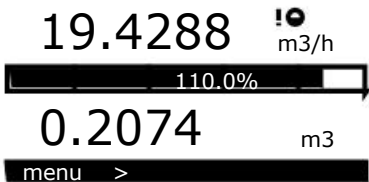

f. 46

## 7. MENU DESCRIPTION

### 7.1 OPTIONS

#### Technical units

- Flow rate volume
- Flow rate time base
- Counters volume
- Pulses volume

#### Measurement frequency

- Measuring time

#### Display

- LCD backlight lev
- Backlight off
- LCD contrast

#### View options

- Last row

#### Full scale flow rate

#### Language

### 7.1.1 TECHNICAL UNITS

- Flow rate volume

Select the volume technical unit for the instant flow rate

- Flow rate time base

Select the time base for the instant flow rate

- Counters volume

Select the volume technical unit for the counters

- Pulses volume

Select the volume unit for the pulses

### 7.1.2 MEASUREMENT FREQUENCY

- Measuring time

Select measuring time of the system between 16 and 120 seconds in battery powered mode.



### 7.1.3 DISPLAY

- LCD backlight lev

Increase or decrease backlight level

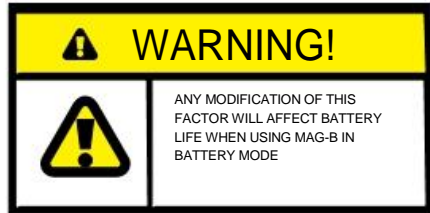

- Backlight off

Increase or decrease shut off time of the backlight of the display



- LCD contrast

Modify the contrast value of the display

### 7.3.4 VIEW OPTIONS

- Last row

Defines the default display information with selection

between:

- T+ total positive counter
- P+ partial positive counter
- T- total negative counter
- P- partial negative counter
- Date and time

7.1.5 FULL SCALE FLOW RATE

Modify the full scale flow rate. Standard full scale flow rate is calculated based a velocity of 5 m/s.

Refer to the below chart for correct selection:

UNIT	EQUIVALENTS
m (2)	
cm3	0.001 dm3
ml	0.001 dm3
dm3	1 dm3
l	1 dm3
dal	10 dm3
hl	100 dm3
m3	1000 dm3
MI	1000000 dm3
in3, cubic inches	1.63871e-2 dm3
oz UK, fl.oz UK	0.02841 dm3
pt UK, pints UK	0.5679 dm3
qt UK, quarts UK	1.1359 dm3
gal UK, gallons UK	4.545771 dm3
gal US, gallons US	3.785333 dm3
ft3, cubic feet	28.31685 dm3
bbl, std barrel	119.238 dm3
bbl oil, oil barrel	158.984 dm3
hcf, hundred cubic feet	2831.685 dm3
kg US, kilo gallon US	3785.333 dm3
Mgl US, Mega gallon US	3785333 dm3
g	0.001 Kg
hg	0.1 Kg
kg	1 Kg
q	100 Kg

UNIT	EQUIVALENTS
t	1000 Kg
oz, once	0.028350 Kg
lb, pounds	0.45359 Kg
ton, short ton	907.18 Kg

7.1.6 LANGUAGE

Select the language of the menu between:

- ENGLISH
- ITALIANO
- ESPAÑOL
- PORTUGUÉS

7.2 COUNTERS

- T+
- P+ (set zero)
- T-
- P- (set zero)

Four different counters are available with MAG converter. Two positive counters, and two negative counters.

Only partial counters can be set to zero.

To set the counters to zero from the MAG software program, go on the READ screen shot, see picture below.

Only partial counters can be set to zero.

In the same screen shot is also displayed a linear graph showing the percentage of the instant flow rate compared to the full scale flow rate set in the converter, indicated below the graph (17,66 m3/h in the example)

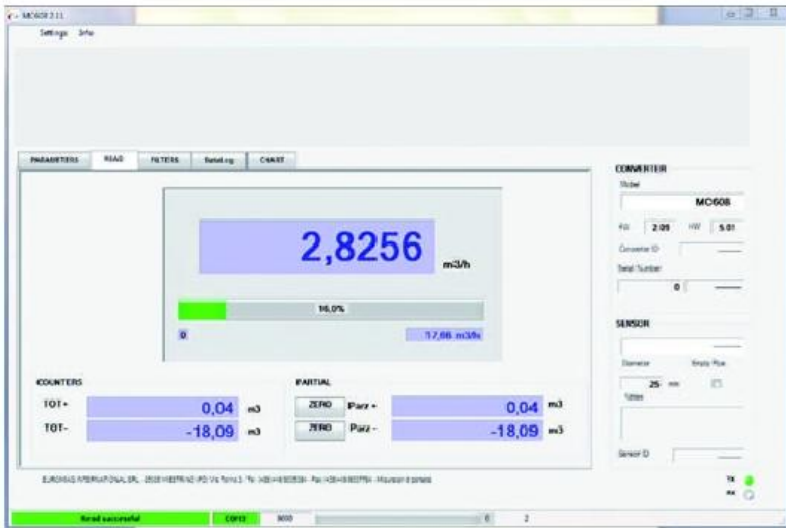

f. 49

### 7.3 PARAMETERS

Ka setup

Diameter Setup

Filters setup

- Flow cut off
- Damping
- Bypass
- Peak cut
- Measure average

Sensor offset

Zero finder

Flowrate alarms

- Max flow th.
- Min flow th.

#### 7.3.1 KA SETUP

It allows to modify the KA calibration factor.

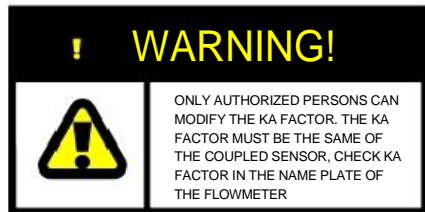

#### 7.3.2 DIAMETER SETUP

Allows diameter modification. In case of Insertion flowmeter, please enter the real internal diameter value of the pipe in this menu.

7.3.3 FILTERS SETUP

NOTE	
	<p>Filters should be adjusted only if strictly necessary. Factory settings are already calibrated for a correct working condition.</p>

- Flow cut off

In this submenu you will find a value as a percentage of the full scale: if the real flow rate is lower than this value, the instrument will show 0 flow.

NOTE	
	<p>Should you need to reduce the flow cut off filter, means the velocity of the liquid is below the recommended one for a good measurement.</p>

- Damping

Increase the stability of the reading by adding an higher average of the displayed values.

To increase the stability, increase the value in this sub menu

- Bypass

In this submenu is entered a value in percentage. Represents a threshold on which the digital filter is NOT calculated. For example:

In case is selected a value of 50%

- IF the flow rate varies 50% more than the previous value
- THEN the flow rate shown will take on a real value
- OTHERWISE the digital filter will be applied, that is to say that the shown flowrate will slowly reach the real value

- Peak cut

In this submenu you will find a value as percentage

of the full scale. If in the flowrate measurement there are peaks, their value will be limited to the value expressed in this submenu. For example, setting the value 10%, high peaks on the flowrate signal will be cut in order not to exceed the 10% of the full scale.

- Measure average

Increase the stability of the reading by enlarging the real measurement filtering.

To increase the stability, increase the value in this sub menu. This filter is not available on the MAG software and can be modified only by authorized personnel.

To read and modify the filters value from the MAG software program, go on the FILTERS screen shot, see picture below

Modify the filters within the indicated range.

NOTE	
	<p>Filters should be adjusted only if strictly necessary. Factory settings are already calibrated for a correct working condition. Filter DEFAULT button will recall factory settings.</p>

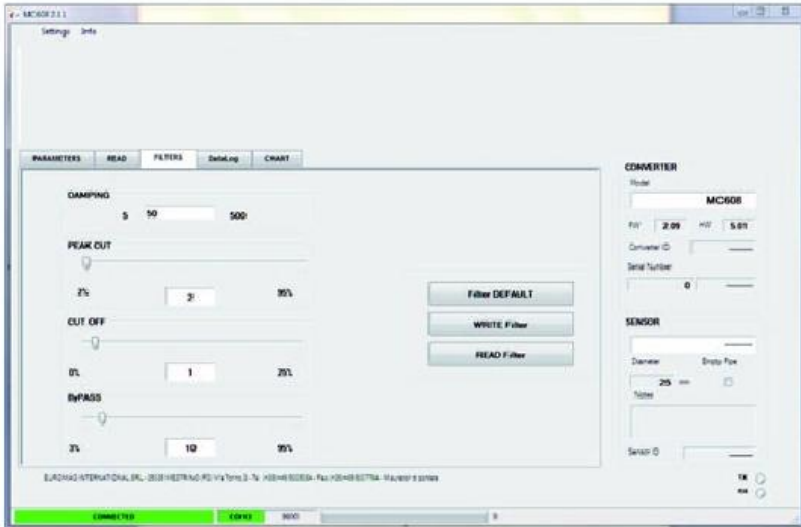

f. 50

### 7.3.4 SENSOR OFFSET

Shows the offset of the flowmeter

### 7.3.5 ZERO FINDER

This setting is used to perform the instrument zero calibration. Before performing the zero calibration, please make sure that:

1. the sensor is full of liquid
2. the liquid is perfectly stationary
3. the sensor has correct electrical grounding

**NOTE**

The MAG has an automatic zero calibration function. Use the zero finder only when strictly necessary

### 7.3.6 FLOWRATE ALARMS

- Max flow th.  
Set the maximum value of flowrate in percentage on the full scale value.

This value is factory disabled. Selectable range goes from 5% to 200% of the full scale value.  
Select 200% to disable the function

- Min flow th.  
Set the minimum value of flowrate in percentage on the full scale value.

This value is factory disabled. Selectable range goes from 1% to 5% of the full scale value.  
Select a value below 1% to disable the function.

**NOTE**

When max or min flow th. are enabled, a symbol will appear on the display in case these values will be reached.

7.4 I/O

Pulses OUT

- Pulse volume
- Pulse T on

Frequency OUT

- Full scale freq.

Prog. OUT

- Enabled/disabled

Prog. IN

- Enabled/disabled

7.4.1 PULSES OUT

- Pulse volume

Select the volume of the pulses.



Pulses volume and duration settings differ between the two models MAG and MAG-B.

- MAG (powered supply version)

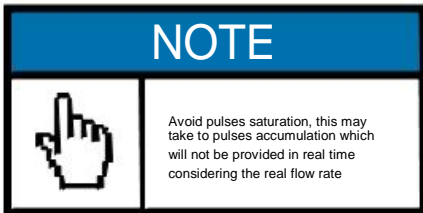

Parameter calculation (values must be re considered to the technical unit of the converter)

[Vp=liters, Tp=seconds; Q=liters/seconds]

- Given Duration:  $Vp > 2Tp / Q$
- Given Volume:  $Tp < 2Vp / Q$

- MAG-B (battery version)

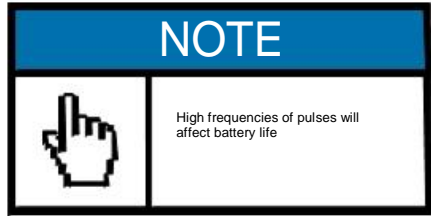

Parameter calculation (values must be re considered to the technical unit of the converter)

[Vp=liters, Tp=seconds; Q=liters/seconds]

- $Tp < 10ms$  →  $Vp > 10Q$
- $10ms < Tp < 100ms$  →  $Vp > 100Q$

- Pulse T on

Select the ON time of the pulse on a range included between 0.5 and 10.000 ms (10seconds)

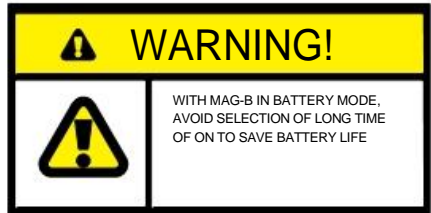

7.4.2 FREQUENCY OUT

- Full scale freq.

Set the maximum frequency corresponding to the full scale flow rate value.

Selectable range: 100 Hz ... 10 KHz

7.4.3 PROG OUT

Selectable between different choices: -

- Max flow alarm
- Min flow alarm
- Reverse flow alarm

7.4.4 PROG IN

Selectable between different choices:

- External P+ zeroing
- External P- zeroing
- External P+ and P- zeroing

7.5 OTHERS

- System info
- Time/date
- Reserved
- Graph
- Simulation
- Communication
  - Baudrate RS485
  - MODBUS address

7.5.1 SYSTEM INFO

Shows the system information. These values are not modifiable by the end user

7.5.2 TIME/DATE

Shows date, time, motherboard temperature, battery condition (for MAG-B battery powered)

7.5.3 RESERVED

Menu under exclusive use of the manufacturer

7.5.4 GRAPH

Shows the graph of the measured flowrate

7.5.5 SIMULATION

The MAG has a built in flow simulator to verify and adjust the pulse output to any connected device system.

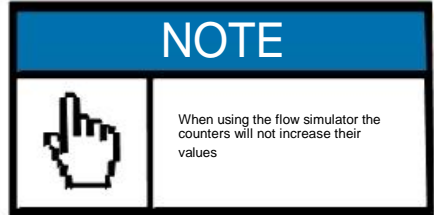

7.5.6 COMMUNICATION

- Baudrate RS485  
Allows to adjust the RS485 baudrate on a range between 2400 and 57600 bps.
- MODBUS address  
Allows to adjust the address of the MODBUS communication between 1 and 255.

7.6 MEMORY

- Load user copy
- Save user copy
- Factory settings
- Datalogger
  - Show last row
  - Full erase
  - Log interval

7.6.1 LOAD USER COPY

Allows to load customized settings

7.6.2 SAVE USER COPY

Allows to save customized settings

7.6.3 LOAD FACTORY SETTINGS

Allows to load factory settings

7.6.4 DATALOGGER

- Show last row

Shows last informations logged. Date, time, counter, instant flow rate, temperature, battery condition

- Full erase

Erase memory of the converter

- Log interval

Select logging interval.

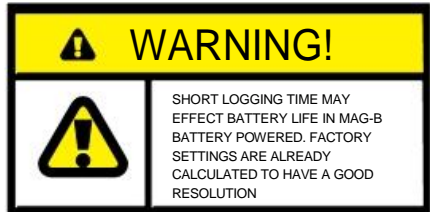
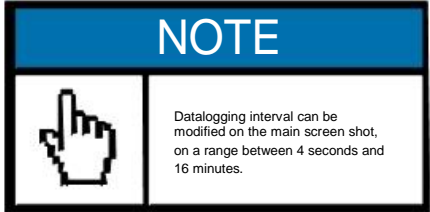
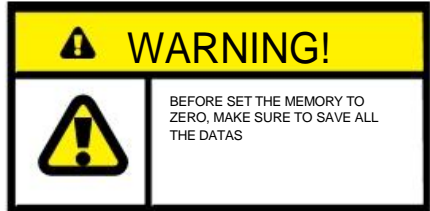

To read and download the memory data from the MAG software program, go on the Datalog screen shot, see picture below.

Select START and END row to read, the "get last log" button will reach the last available log.

Press the READ Log button to download the data.

Press "SAVE CSV" to save data on your PC in CSV format.

Press "Reset DataLog" button to full erase the memory of the converter.

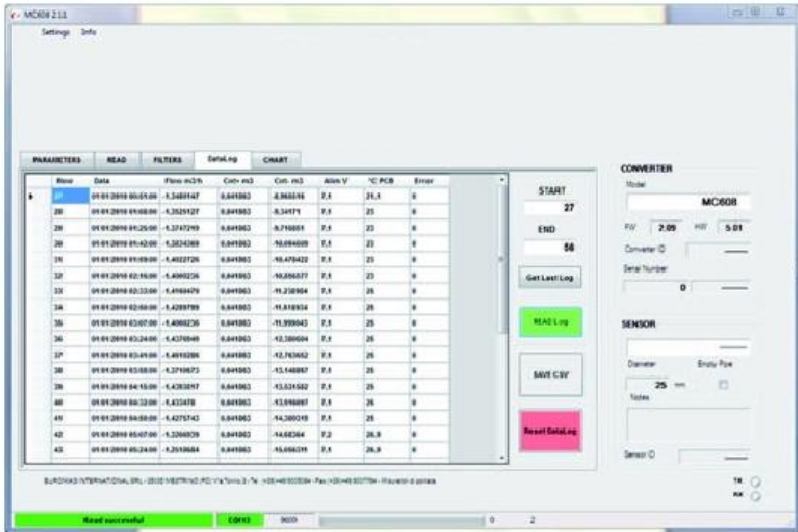

f. 51

After reading the data, an instant graph is also available by going on the CHART screen shot, see picture below.

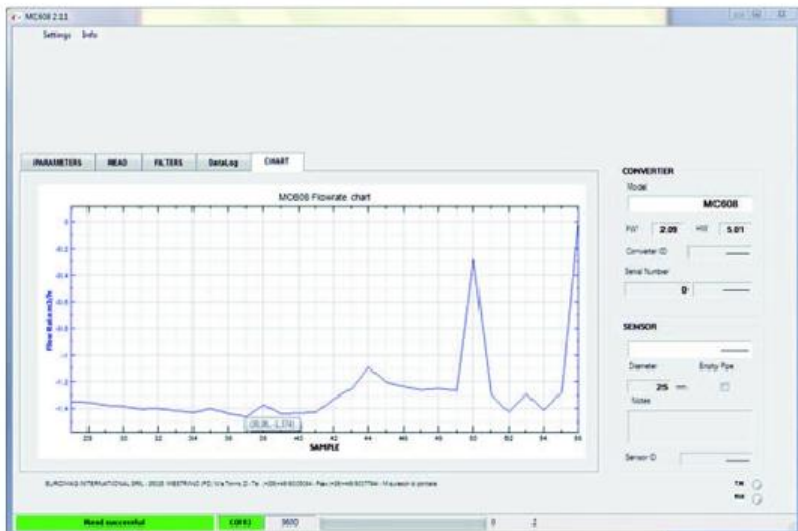

f. 52



## 8. RETURNING A FLOWMETER FOR CHECK UP AND REPAIR

The device was carefully manufactured and has passed rigorous testing before leaving the factory. If correctly installed and maintained, the event of a malfunction should be highly unlikely.

Should you nevertheless need to return a device for inspection or repair, please pay strict attention to the following points:

- Due to statutory regulations on environmental protection and safeguarding the health and safety of our personnel, manufacturer may only handle, test and repair returned devices that have been in contact with products without risk to personnel and environment
- This means that the manufacturer can only service this device if it is accompanied by the following certificate (see next section) confirming that the device is safe to handle.

---



---

### REPAIR APPLICATION FORM

---

Company name: \_\_\_\_\_

Company address: \_\_\_\_\_

Tel.: \_\_\_\_\_ Fax.: \_\_\_\_\_

Type of sensor/converter: \_\_\_\_\_ Serial number No.: \_\_\_\_\_

Type of liquid: \_\_\_\_\_ Internal cleaning: (Y / N) \_\_\_\_\_

Claim: \_\_\_\_\_

\_\_\_\_\_

\_\_\_\_\_

We hereby confirm that there is no risk to persons or the environment through any residual media contained in the device when it is returned.

Date: \_\_\_\_\_

Company stamp: \_\_\_\_\_ Signature: \_\_\_\_\_





9. APPENDIX - TROUBLESHOOTING

SYMPTOMS	POSSIBLE REMEDIES
Converter is showing a flowrate even with steady flow.	<p>Check if the sensor and liquid are correctly grounded.</p> <p>Check that the sensor is full with liquid.</p> <p>Electrical conductivity of the liquid is too low or is not compatible with the material used for the sensor electrodes.</p> <p>Perform manual zero finder if requested (Menu - Parameters, sub menu - zero finder)</p>

Flow reading is highly unstable.	<p>Check if the sensor and liquid are correctly grounded.</p> <p>There is air in the pipe, try to avoid the creation of bubbles selecting a more suitable position for the sensor (see installation paragraph).</p> <p>Only if necessary, set the filters as follows:</p> <ul style="list-style-type: none"> <li>• Set Damping to 150</li> <li>• Reduce peak cut filter</li> <li>• Increase Bypass filter</li> </ul>
----------------------------------	--

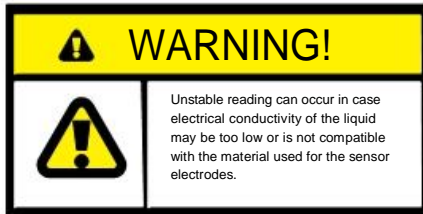

External pulse totalizer shows results different from what is expected.	Test the output with the internal flow simulator and the converter-pulse counter system simulating a flowrate with System > Simulation.
The display is off and does not turn on.	There is no voltage supply, or the voltage supply is mistaken. Check the power supply voltage on the name plate of the converter. In case of MAG-B check the battery life and replace the battery pack.
Liquid flowing an pipe full - but NO reading	Reduce the flow cut off filter (factory settings is 2% of the full scale)

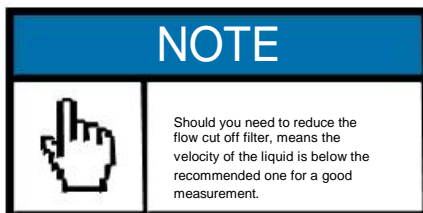

MAG

B METERS SRL  
Via Friuli, 3  
33050 Gonars  
UDINE – ITALY  
Tel 0039 0432 931415  
Fax 0039 0432 992661  
[www.bmeters.com](http://www.bmeters.com)  
[info@bmeters.com](mailto:info@bmeters.com)

---